

591T Series Electronic Faucet with Surface Mount Control Box

TECK[®]
COMMERCIAL

DELTA[®]

SPECIFICATION: (EXAMPLE)

- Supplied as complete product
- **H₂Optics**[®] Technology – no external adjustments required
- Chrome-plated **CAST** 102 mm (4") spout with integral sensor
- **Battery** (4 "C" cell) or **Hardwire** (24VAC) infrared electronic handwash system
- Adjustable sensing range and timeout
- Surface mount housing
- Mixing valve required (order separately)
- Serviceable filter screen upstream of the solenoid valve
- and... with... (specify battery or hardwire)
- with... (add outlet required)
- with... (for hardwire with battery backup – specify separately – see next page)
- with... (transformer required for hardwire operation – specify separately – see next page)

591T1250



Engineer/Architect Approval

Model Specified:

Approval:

Date:

MODEL NUMBER EXAMPLE:

Configurations vary, see below for availability.

591T0220TR

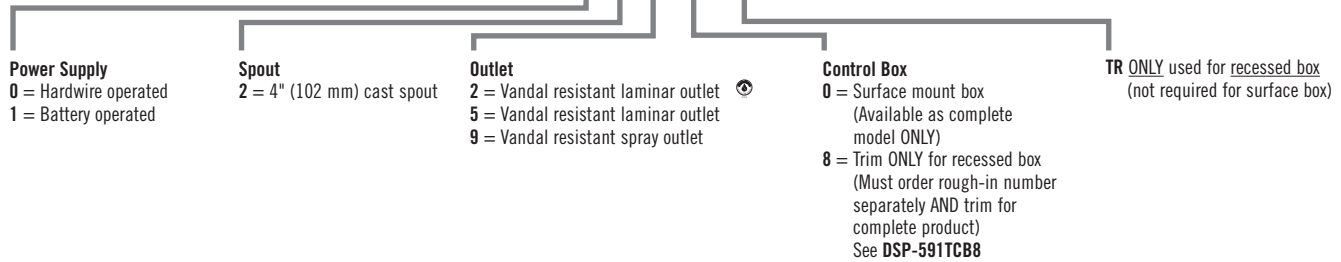

AVAILABLE MODELS	SURFACE MOUNT CONTROL BOX	
	HARDWIRE	BATTERY OPERATED
2 Deckmount 4" Spout	2 Deckmount 4" Spout	
2 Vandal Resistant Laminar Outlet 1.5 gpm (5.7 L/min)	591T0220	591T1220
5 Vandal Resistant Laminar Outlet 0.5 gpm (1.9 L/min)	591T0250	591T1250
9 Vandal Resistant Spray Outlet 0.35 gpm (1.32 L/min)	591T0290	591T1290

Refer to www.specselect.com for individual models.
Batteries included on all battery models.

Note: Use this page front and back, with specification drawing page referenced above, as product submittal sheets.
Flow Rates are at 60 PSI.

Delta reserves the right (1) to make changes in specifications and materials, and (2) to change or discontinue models, both without notice or obligation.
Dimensions are for reference only. See current full-line price book or www.specselect.com for finish options and product availability.



DSP-591TCB0 Rev. D

591T Series Electronic Faucet with Surface Mount Control Box

TECK
COMMERCIAL

DELTA

APPROVALS:

- CSA certified
- Complies to ASME A112.18.1/CSA B125.1
-  Indicates compliance to ICC/ANSI A117.1
-  Outlet option 2 is EPA WaterSense listed
- Verified compliant with 0.25% weighted average Pb content regulations

(Contact Delta Representative for State and/or Local Approvals.)

Patented

FLOW RATE VS PRESSURE

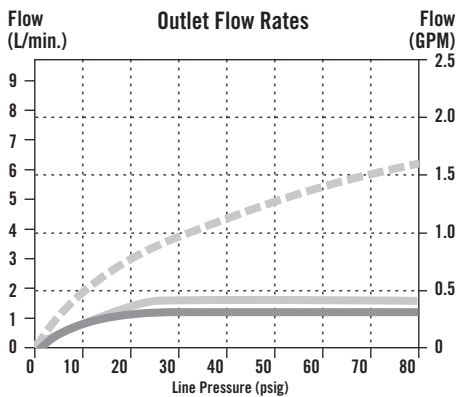

Spout Outlets

-  No. 2 Laminar Flow Outlet
-  No. 5 Flow Control Outlet
-  No. 9 Outlet

FRONT VIEW

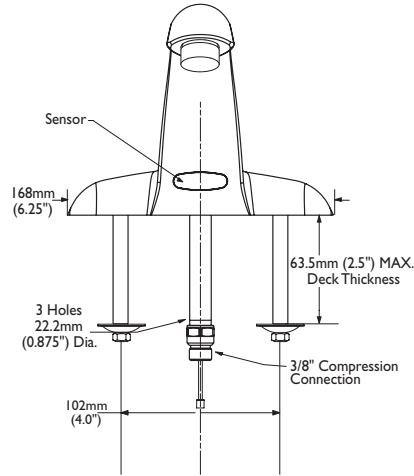

SIDE VIEW

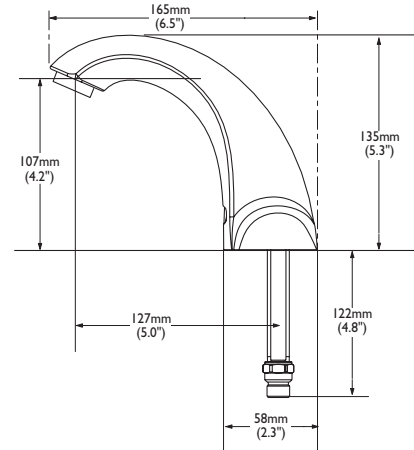

TYPICAL INSTALLATION

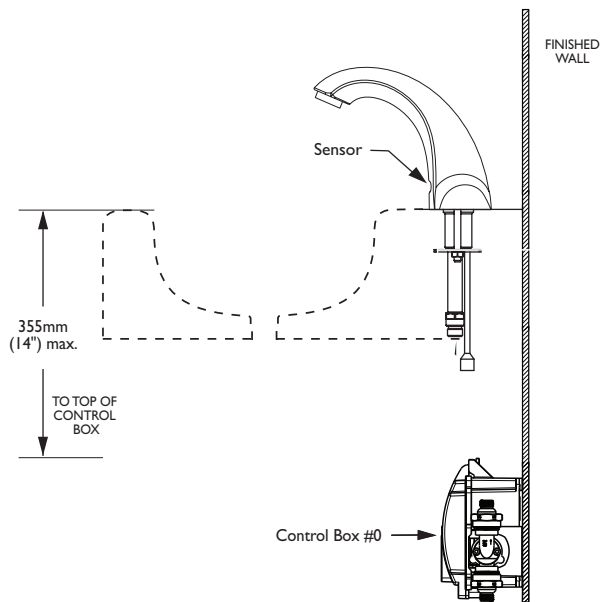

AVAILABLE OPTIONS FOR FIELD CONVERSION

- 061047A**
Hardwire with Battery Backup
See DSP-BB for detailed specification.
- 060651A**
3 Position Switch
See DSP-ELACC for detailed specification.

Note: Measurements may vary \pm 6mm (0.25")

Refer to www.specselect.com for individual models.
Product supplied as shown by solid lines. All items shown by dotted lines supplied by others.

DSP-591TCB0 Rev. D

Delta reserves the right (1) to make changes in specifications and materials, and (2) to change or discontinue models, both without notice or obligation. Dimensions are for reference only. See current full-line price book or www.specselect.com for finish options and product availability.

591T Series Electronic Faucet with Surface Mount Control Box

TECK[®]
COMMERCIAL



SENSOR CLEARANCE

For above deck mounted sinks, the sensor requires a clearance.

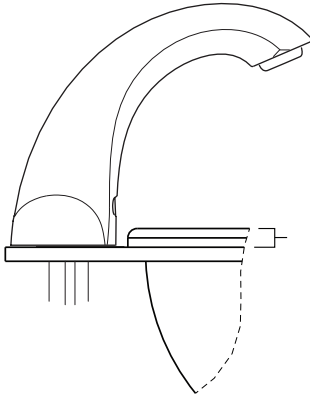

For sensor clearance:
10 mm (0.4") maximum sink lip height from deck

OPERATION:

- Hands free (touchless) operation.
- Water flows when sensor is activated.
- Water flow stops upon de-activation of sensor.
- Adjustable auto shut-off feature. Factory set to 45 seconds. Will reset once obstruction is removed.
- Adjustable sensing distance 76 to 381mm (3" to 15") factory set to 229mm (9") (± 3.0")
- Low battery audible beep (for battery models only) will activate after faucet shuts off when approximately 1500 cycles remain.
- Metering mode with selectable flow times of 7 seconds to 4 minutes, factory set off.
- Periodic Rinse feature, time adjustable in 6 hour increments up to 2 days. Selectable rinsing lengths from 10 to 180 seconds. Factory set off.

NOTE 1: For optimum performance of this product, we recommend a system pressure between 20 and 80 PSI static. This product will operate up to a maximum of 125 PSI static per ANSI and CSA requirements. However, we do not recommend pressures above 80 PSI. Thermal expansion or leaking pressure reducing valves may require use of expansion tanks or relief valves to ensure your system never exceeds its maximum intended pressure setting.

NOTE 2: Designed for routine 171°F (77°C) disinfection cycles up to 30 minutes.

OPTIONAL ACCESSORIES

✓	TRANSFORMERS
	060704A 110 to 24 VAC Class 2 20 VA (Up to 5 Electronic Valves)
	060771A 110 to 24 VAC Class 2 40 VA (Up to 10 Electronic Valves)
✓	CORDS
	061256A 36" Cable Extension

Note: Measurements may vary ± 6mm (0.25")

Refer to www.specselect.com for individual models.
Product supplied as shown by solid lines. All items shown by dotted lines supplied by others.

Delta reserves the right (1) to make changes in specifications and materials, and (2) to change or discontinue models, both without notice or obligation. Dimensions are for reference only. See current full-line price book or www.specselect.com for finish options and product availability.

DSP-591TCB0 Rev. D

591T Series Electronic Faucet with Surface Mount Control Box

TECK
COMMERCIAL

DELTA

SURFACE MOUNT CONTROL BOX #0

591T SERIES

✓	PRODUCT NO.					VALVE TYPE	COVER
	591T	0	2		0	Deckmount Handwash Hardwire	Surface Mount Control Housing
	591T	1	2		0	Deckmount Handwash Battery	Surface Mount Control Housing

VANDAL RESISTANT SURFACE MOUNT CONTROL HOUSING

591T SERIES

Battery Operated – Box shown.

Hardwire Version comes complete with Watertight Connector and Hardwire Converter 24 VAC to 6.4 VDC.

Hardwire with Battery Backup (Available option for field conversion) comes complete with Watertight Connector, Hardwire Converter 24 VAC to 5 VDC and 9 V battery. See **DSP-BB** for detailed specification.

Recommended
381 mm (15" max.)
to top of counter

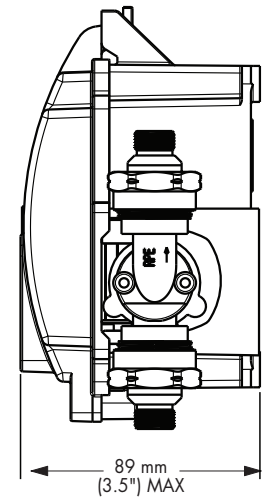
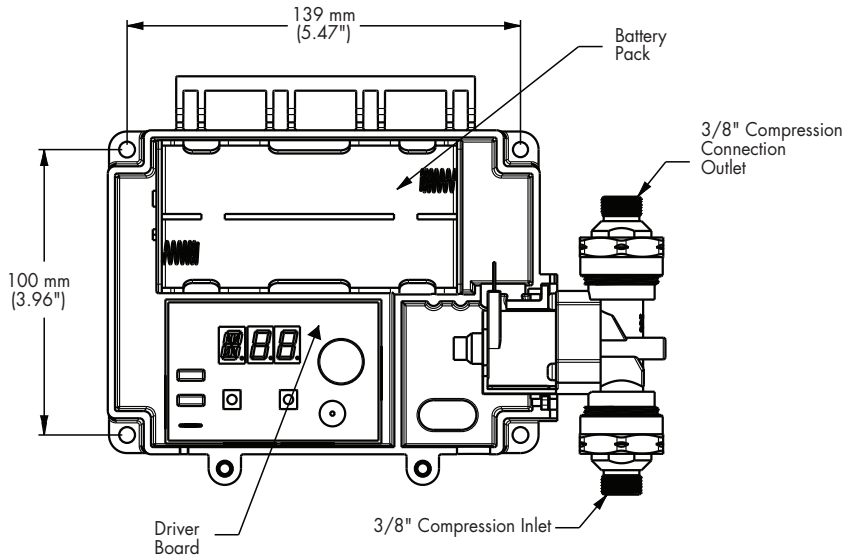
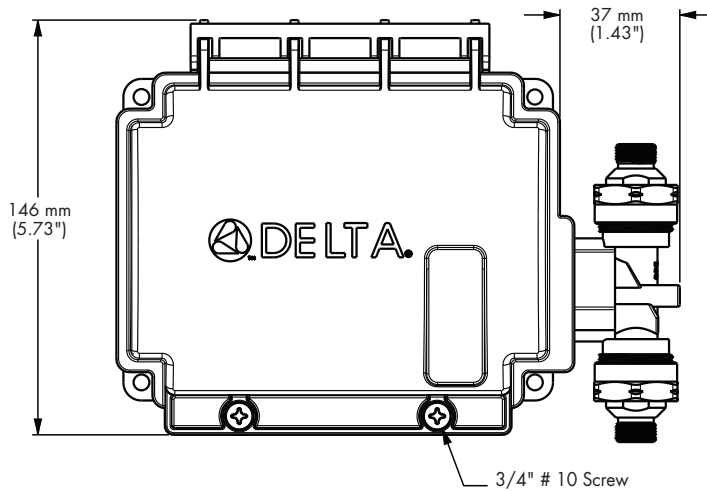

BRAIDED HOSE

Note: Hose connections supplied between Solenoid Valve and Spout

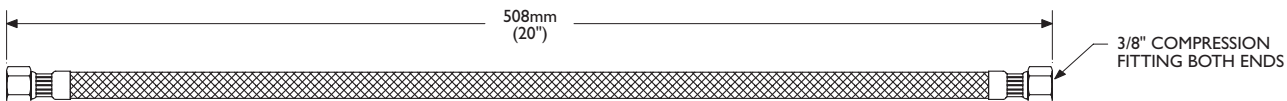

Note: Measurements may vary ± 6 mm (0.25")
Refer to www.specselect.com for individual models.

DSP-591TCB0 Rev. D

Delta reserves the right (1) to make changes in specifications and materials, and (2) to change or discontinue models, both without notice or obligation. Dimensions are for reference only. See current full-line price book or www.specselect.com for finish options and product availability.